



LIGHTGLASS

PRODUCT DESCRIPTION

LIGHTGLASS is a simulated window, an architectural element that brings the experience of a daylit window into any space. Through the integration of the latest LED lighting technology into the form and materials of a window, LIGHTGLASS is nearly indiscernible from a real window.

PERFORMANCE SPECIFICATION

A patented, prefabricated UL-listed lighting system with the appearance of a window, with integrated aluminum extrusion, glass, gasketing, and LED light engine delivering 94+ CRI, UGR below 12, no perceptible flicker, greater than 89% uniformity, and an L70 rating of over 100,000 hours. LED drivers included, and a system warranty of a minimum of 5 years.

AT A GLANCE:

Color Temp. Range	2200K - 6500K
Min. Required Depth	5.375"
Wet Rating	UL Dry / damp locations only
Voltage	100 - 277 VAC
CRI	94+
R9	65+
Color-Binning	3 Step MacAdam Ellipse
Distribution	Lambertian
Rated Life	L70 100,000 Hours
Dimming / Control	0-10V, 2-channel 0-10V Tunable White
Operating Temp.	-20°C to +50°C / -4°F to +122°F
Warranty	5 Years
ETL	Conforms To UL STD 1598
CSA	CSA standard is 22.2 No. 250.0

PROJECT:

TYPE:

QUANTITY:

DATE:

SPECIFIER:



COMMON APPLICATIONS:

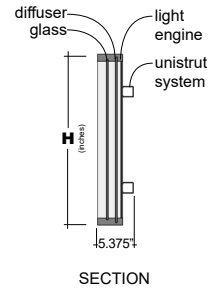
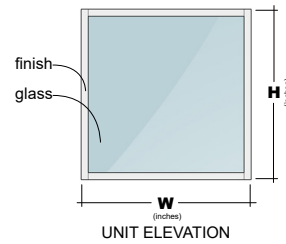
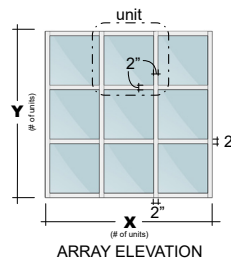
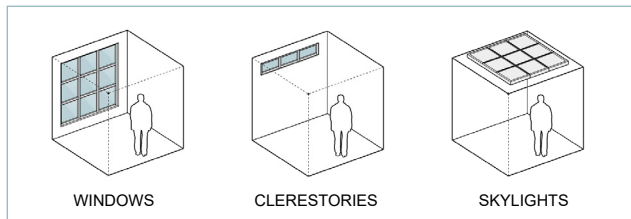

PART BUILDER:

SERIES	UNIT SIZE	LAYOUT	GLASS	FRAME WIDTH	COLOR TEMP	DRIVER	MOUNTING	FINISH	OPTIONS
A	H x W (inches) (inches) Dimensions must be provided in 1" increments Maximum area no greater than 24ft ² <small>*Refer to following page for additional sizing information</small>	Y x X (# of units) (# of units) MO : Mosaic* <small>*Contact LIGHTGLASS to finalize part number</small>	G : Clear	2 : 2" width	22 : 2200K 27 : 2700K 35 : 3500K 40 : 4000K 50 : 5000K 65 : 6500K TW : Tunable White	R : Remote 2 Channel 0-10V** I : Integral* 2 Channel 0-10V <small>*2" Frame Width and Unit Width (W) of 36" or more are required for Integral driver. **Remote Driver required for SunDial Controller</small>	WX : Wall Recessed WU : Wall Unistrut Clips* CU : Ceiling Unistrut Clips* <small>*Unistrut Clip Mounting recommended. Also used for recess install.</small>	A : Clear Anodized B : Dark Bronze W : White #### : Custom RAL #	NO : None M1 : Muntin 1 M2 : Muntin 2 M3 : Muntin 3 NF : Non-ferrous (MRI safe) CP : Chicago Plenum* AL : Anti-Ligature** DS : Daylight Savings (SunDial Control) <small>*Unit depth increases to 5.25" **Cannot be combined with M1, M2, M3, NF</small>

SunDial Controller:
 Integrated Automatic Daylight Simulation
(See pg. 6 for more information)



LIGHTGLASS

SERIES

Array (A) refers to installations in which LIGHTGLASS is mounted as a group. **Standalone (S)** refers to installations in which each LIGHTGLASS unit is mounted in its own discrete opening within a wall or ceiling and not physically touching other LIGHTGLASS units.

[See [Specification Sheet: Array](#) for more information - see /resources.]

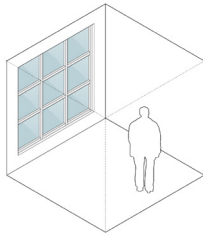

A - ARRAY
 Units are installed in groups.

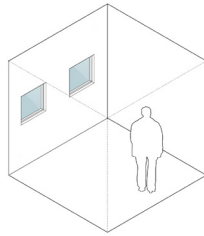

S - STANDALONE
 Units are installed separately.
 [See [Specification Sheet: Standalone](#) for more information.]

UNIT SIZE

Units can be manufactured to the standard sizes listed below. For custom sizing, see Custom Sizes section.

STANDARD SIZES

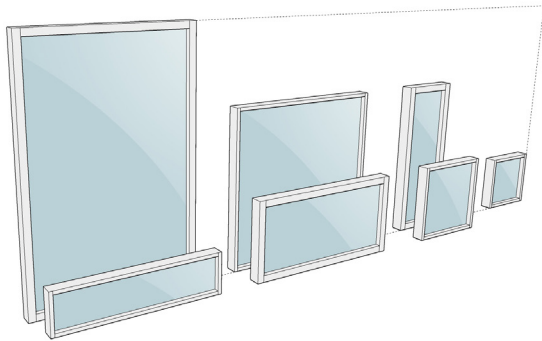

STANDARD SIZES	LUMENS	WATTS	LUMENS / WATT	WEIGHT (LBS)	DRIVERS
72x48	12,835	102.51	125	138	2
48x48	8,010	69.84	115	92	1
48x24	3,628	37.17	98	47	1
48x18	2,601	29.00	90	35	1
48x12	1,603	20.83	77	24	1
42x42*	5,896	54.57	108	92	1
42x18*	2,230	26.16	85	31	1
24x24	1,638	21.54	76	24	1
18x18*	841	14.79	57	14	1

* Fits standard ACT ceiling grid dimensions when used with shrouds. See [Shroud](#) section for more information.

CUSTOM SIZES

Rectangular units must be specified in 1" increments between 12" minimum and 96" maximum dimensions from the unit's outer dimension, with a total area from 1ft² minimum to 24ft² maximum.

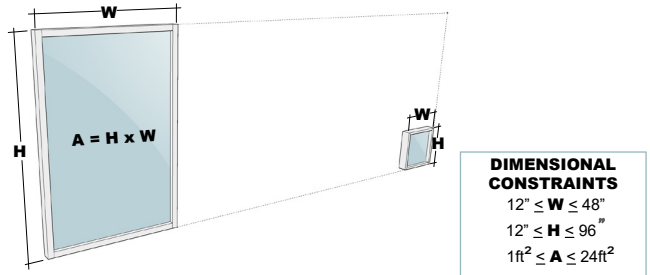

CUSTOM SIZES	LUMENS	WATTS	LUMENS / WATT	WEIGHT (LBS)	DRIVERS
H x W	Data available upon request				

LAYOUT

Units can be clustered together to cover large surface areas. Aluminum faceplates that connect adjacent units and form the perimeter are 2" wide. When calculating the outer dimensions of an array use the following steps:

1. Add up the unit heights (**H**) and widths (**W**).
2. Subtract 2" for each shared faceplate between units in those respective directions.

For example, (9) 24" x 24" LIGHTGLASS units in a 3x3 array will require a rough opening approximately 68" high by 68" wide.

$X = (24" [\text{unit width}] \times 3 [\text{\# of units}]) - (2" [\text{faceplate width}] \times 2 [\text{\# of shared faceplates}])$

Y x X

Units are installed in groups of uniform sizes **X** units wide by **Y** units tall.

(3 x 3 shown)

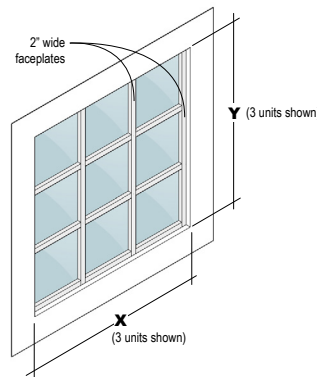

MO - MOSAIC

Units are installed in groups of varying sizes.

(Contact LIGHTGLASS to finalize part builder)

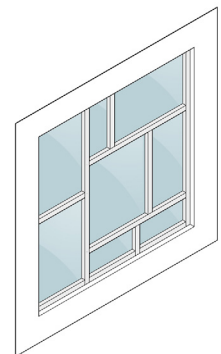

GLASS

Clear 1/4" thick laminated or tempered glass with a light transmittance of 88% comes pre-assembled within each unit.

*Ceiling Units use laminated glass whereas Wall Units use tempered glass

LIGHTGLASS

COLOR TEMPERATURE

CCT (Correlated Color Temperature) ranges between 2200K and 6500K as a standard feature. It's possible to specify a single static CCT or dynamic **Tunable White**: user-controlled changes in CCT, used to recreate the dynamic lighting conditions of a typical solar day. This can be achieved by pairing LIGHTGLASS with a 3rd party control system.

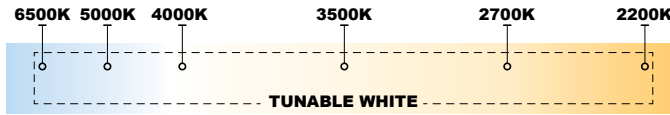

SPECTRA

LIGHTGLASS is designed to produce broad-spectrum light, similar to sunlight. Warm and cool tunable LEDs work in unison to create a dynamic and immersive circadian lighting experience.

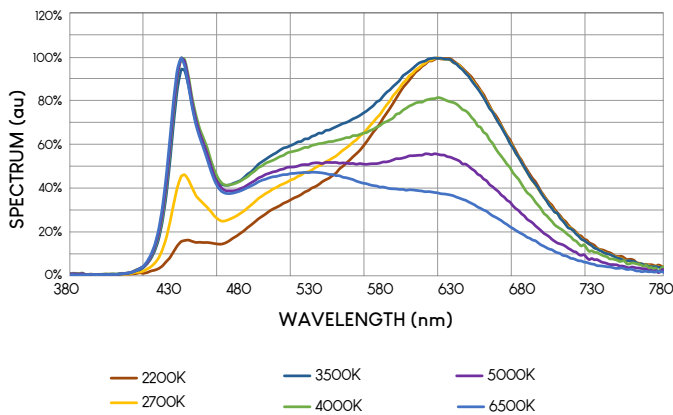

LIGHT DISTRIBUTION

Lambertian

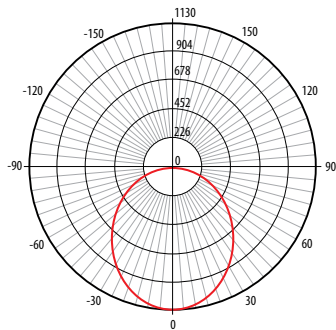

LIGHT QUALITY

FLICKER

LIGHTGLASS has no perceptible flicker.
i. Meet: CEC title 24 JA8 & JA10, IEEE PAR 1789-2015
ii. The product utilize driver and LED load 1 and 2 is compliant with CEC title 24 JA8 and IEEE PAR 1789-2015 Recommended Practice 1 in the dimming range from 55mA to 150mA.

UGR (Unified Glare Rating)

LIGHTGLASS units have a UGR of <12. UGR is a method of calculating glare from light sources. This rating helps determine how likely a light source is to cause visual discomfort. This classification ranges from 5 to 40, with low numbers indicating low glare.

CIRCADIAN STIMULUS

The *Lighting Research Center* has published a set of research and tools to help specifiers create a circadian stimulus in the built environment. LIGHTGLASS accounts for this research in its design, providing the recommended levels of vertical illuminance at eye level when applied as a clerestory or window. Units produce short wavelength 450nm-490nm light at higher CCTs, optimized for creating a circadian response.

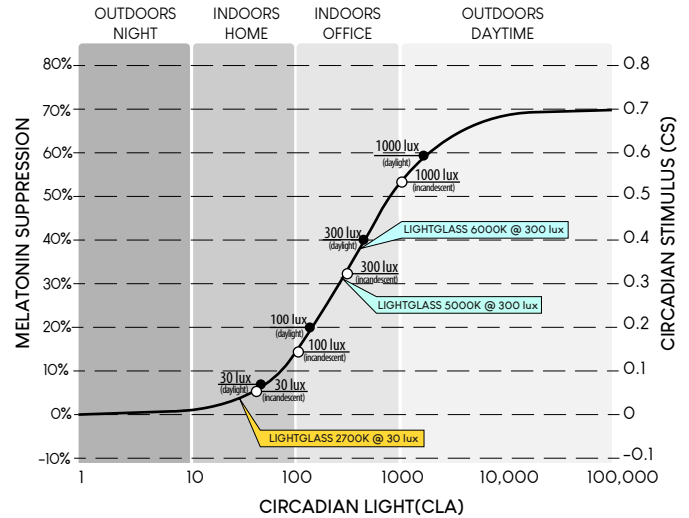

EML (EQUIVALENT MELANOPIC LUX)

The international WELL Building Institute specifies that the biological effects of light on humans can be measured in Equivalent Melanopic Lux (EML), a proposed alternate metric to Circadian Stimulus that is weighted to the ipRGCs instead of to the cones, which is the case with traditional lux. This weighting factor is defined as the Melanopic Ratio (M/P Ratio). During Performance Verification, EML is measured on the vertical plane at eye level of the occupant. LIGHTGLASS meets the EML requirements for Working environments, Learning Environments, Living Environments, and Break rooms.

See LIGHTGLASS' M/P Ratio and EML for each CCT at high and low intensities in the table below:

CCT	2200K	2700K	3000K	3500K	4000K	5000K	6500K
M/P Ratio	0.40	0.55	0.63	0.74	0.83	0.96	1.08
EML (300 lux)	120	166	190	223	249	288	325
EML (30 lux)	12	16.6	19	22.3	24.9	28.8	32.5

BRIGHTNESS UNIFORMITY

Diagram showing lux levels relative to brightest point on the illuminated plane.

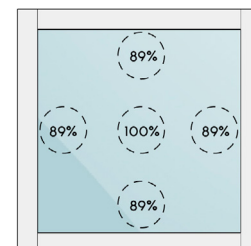

TM30 COLOR FIDELITY

Diagrams shows the average chromaticity shift for the samples within each of 16 hue bins. The values are normalized so that the reference is a circle.

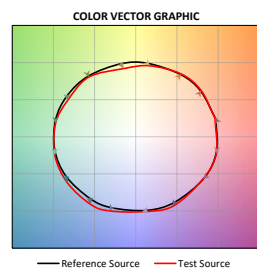
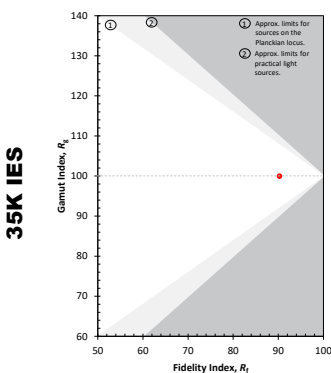
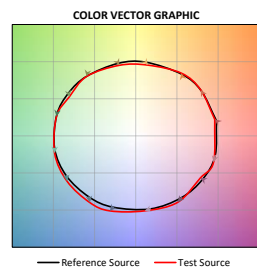
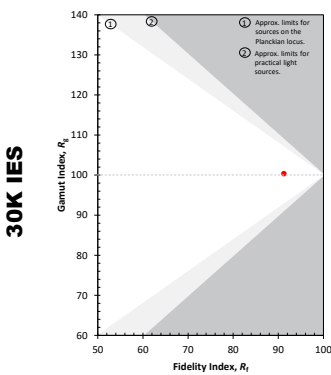
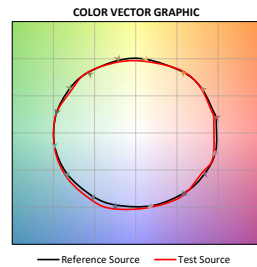
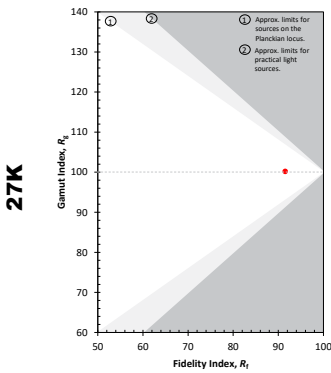
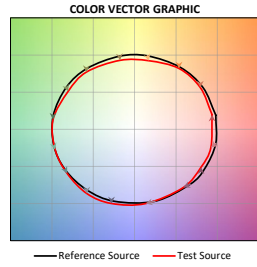
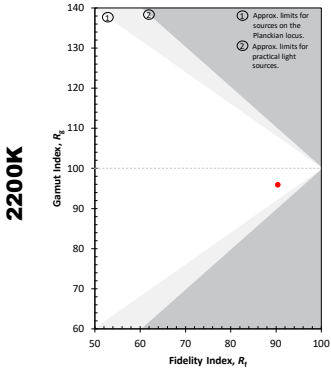

This plot shows a comparison of the R_g and R_i values relative to the range of possible values

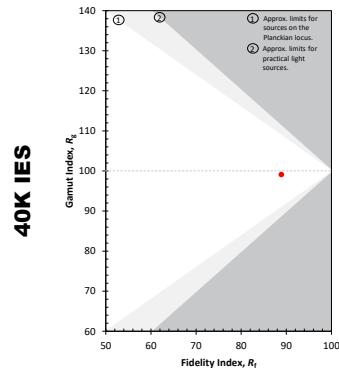

This plot shows the average chromaticity shift for the samples within each of 16 hue bins. The values are normalized so that the reference is a circle.

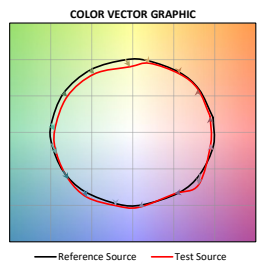
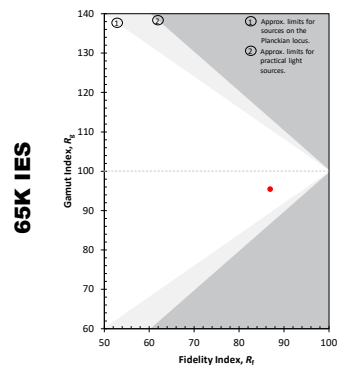
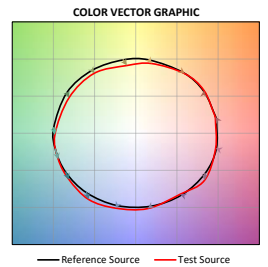
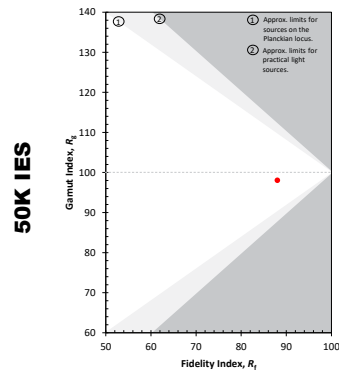
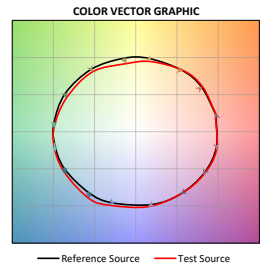

VOLTAGE TO CCT

Chart showing 0 - 10V control for Tunable White.

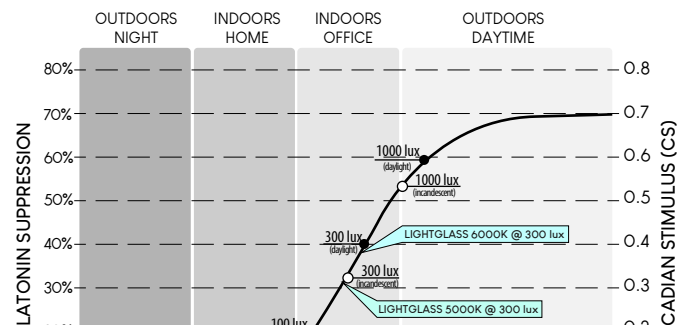

SunDial Controller

SunDial is a turn-key circadian controller developed by LIGHTGLASS that enables any LIGHTGLASS configuration to automatically simulate the changing colors and intensities of daylight throughout the day, without any on-site commissioning or programming. Each Standalone (S) unit ships with its own pre-wired driver.

- Pre-programmed daylight schedule with a built-in clock automatically adjusts the CCT and intensity of LIGHTGLASS throughout the day
- Will automatically adjust for daylight savings time if (DS) is specified in the Options column of the part number
- No additional wiring, commissioning, or programming required. Simply deliver power to the LIGHTGLASS driver, and SunDial will automatically begin operating.
- Controller hardware is installed remotely in its own box, can be attached to the remote driver box provided by LIGHTGLASS, and is powered directly from the auxiliary power output provided by the LED driver.
- Integrated battery backup retains the time of day in the event of losing power. Battery rated for 25 years.
- One 0-10V input channel available to add manual dimming overrides or sensors if desired. (see SunDial wiring guide)

Dimming Schedule

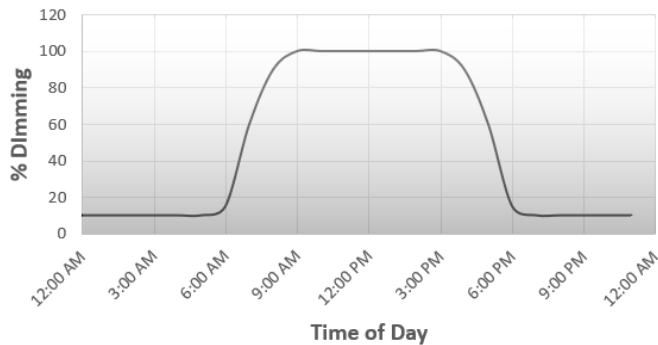

CCT Schedule

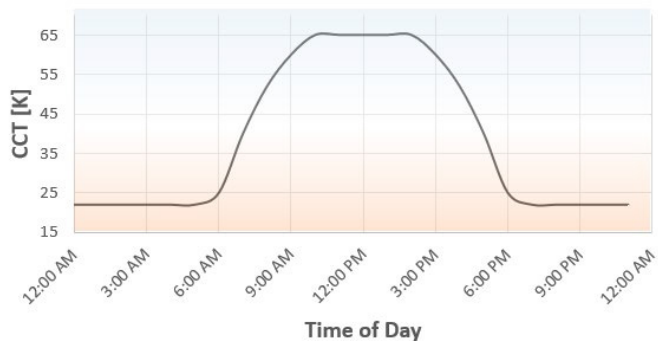

How to Specify

- In the CCT column of the part number, select the time zone where the LIGHTGLASS will be installed
- In the Options column of the part number, select DS for automatic Daylight Savings time adjustment. Leave blank if daylight savings time adjustment is not desired

DRIVER BOX with SUNDIAL CONTROLLER

EC must wire the unit power and the dimmer override wires. All other connections are pre-wired by LIGHTGLASS. (See Wiring Guide for details)

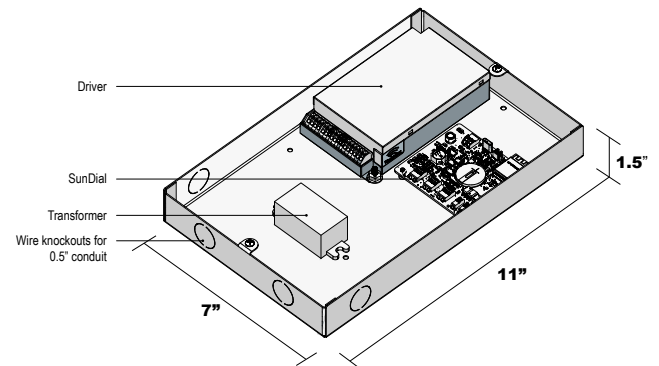

LIGHTGLASS

DRIVERS

Each Array (A) ships with one driver per individual fixture.

- **Remote (R)** 2-channel 0-10V analog drivers are available for all units and are mounted remotely. See [Wire Gauge Distance](#) table for wiring limits. See [Remote Wiring Guide](#) for more information.
- **Remote DALI 2 Type 8 (D)** digital drivers are available for all units and are mounted remotely. See [Wire Gauge Distance](#) table for wiring limits.
- **Integral (I)** 2-channel 0-10V analog drivers are embedded within the unit's frame and accessible via a removable faceplate at the top of the unit. Integral Drivers are only available for a single row of units (Layout X = 1) and with a minimum unit width (**W**) of 36". See [Integral Wiring Guide](#) for more information.

DIMMING METHOD

In the range of 200-1500mA, the current operates in continuous mode;

In the range of 0-200mA, the current operates in PWM dimming mode, and PWM frequency 3.6KHZ.

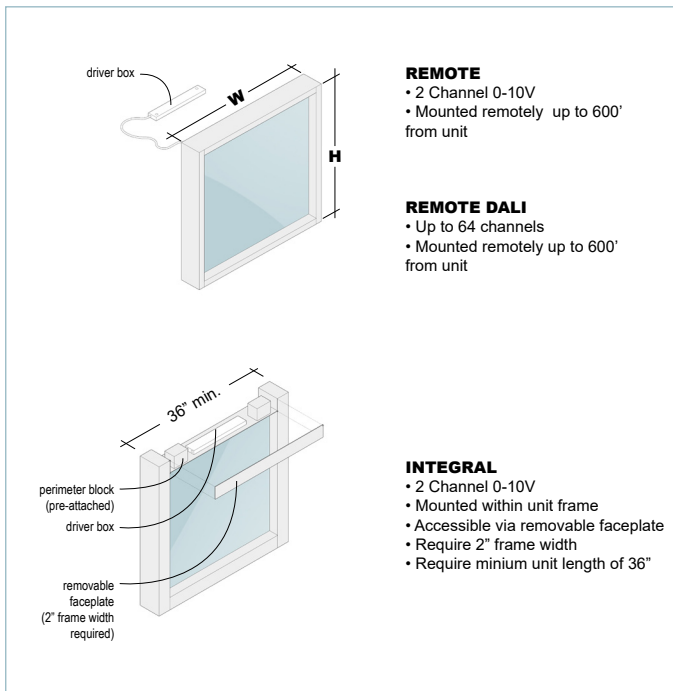

DRIVER BOX

Multiple drivers can fit within a pre-assembled and provided driver box.

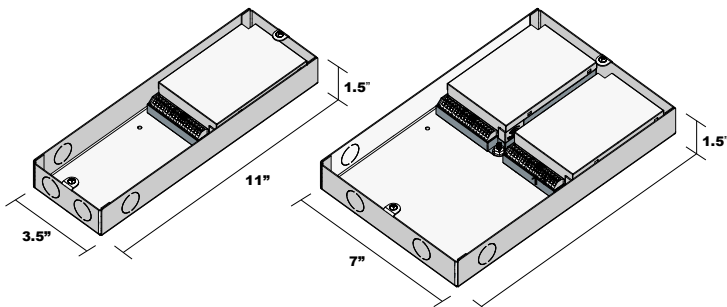

WIRE GAUGE DISTANCE

See below for proper wire gauge based on remote driver distances.

Copper Wire Gauge	20	18	16	14
Max Remote Driver Distance (ft)	150	240	370	600

WIRING

Direct Current (DC) power and the appropriate LED driver are required to ensure proper functionality of the LIGHTGLASS unit.

Pre-installed wiring exiting the unit, referred to as the wiring whip, is located at the top left hand corner of each unit, as shown. Refer to the [Installation Guide](#) for complete wiring information.

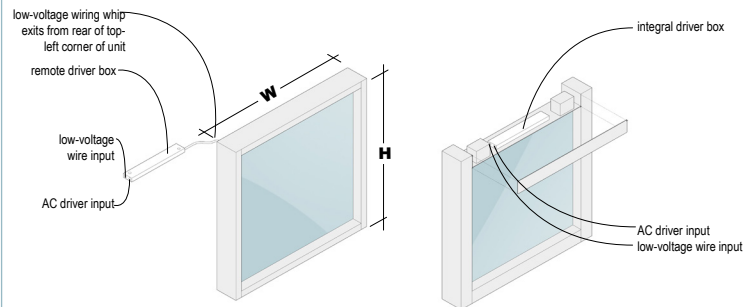

MOUNTING

Each unit must be fastened to structural elements able to support its weight.

- **Recessed (X)** mounting indicates the front face of the unit lies behind the finish face of partitions or ceilings. The unit is placed into a framed opening and is fastened directly to framing or similar structural elements via screws. At 3.75" deep, units are designed to fit within a standard 2x4 partition.

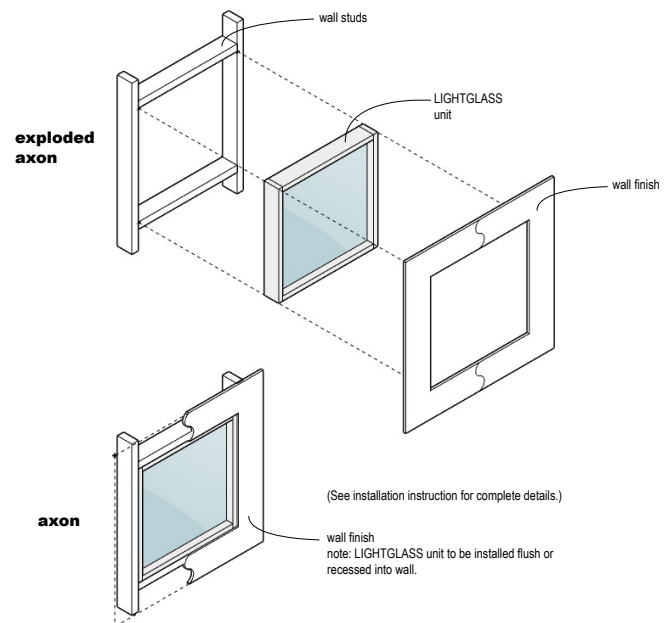

LIGHTGLASS

MOUNTING (continued)

- **Unistrut Clip (U)** mounting indicates a unistrut channel fastened to structure before fastening the unit to the channel via provided clips. This mounting method requires a minimum mounting depth of 5" in walls and ceilings.

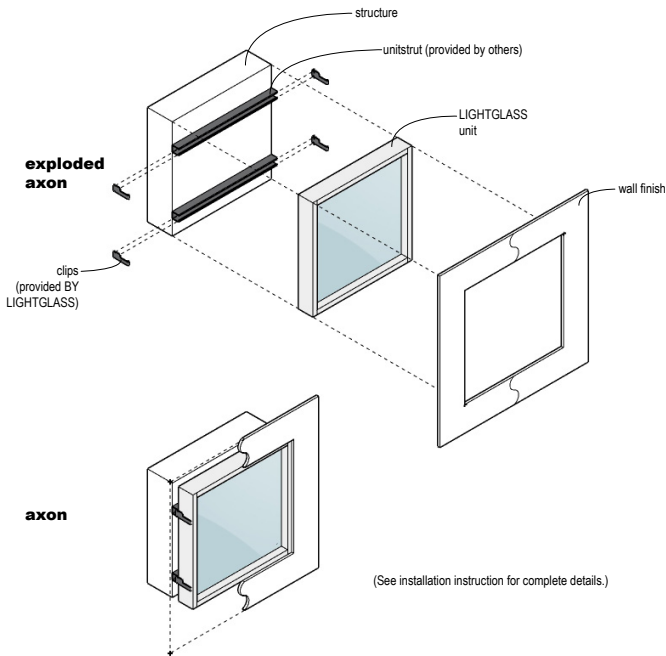

FINISH

Each unit is composed of extruded aluminum and comes in multiple durable finishes:

- **Clear Anodized (A)** is an anti-microbial gloss finish that showcases the aluminum's natural finish.
- **Dark Bronze (B)** is a powder coat applied paint with satin finish.
- **White (W)** is a powder coat applied paint with satin finish.
- **RAL (####)** is a base color of any provided 4-digit RAL number with a protective oxide layer with a satin finish.

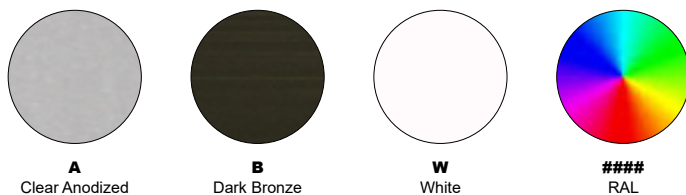

OPTIONS: MUNTINS

Muntins are slim, 0.5" x 0.5" square aluminum extrusions finished to match the unit frame and applied to the front of the glass. See below for available muntin configurations per standard unit sizes.

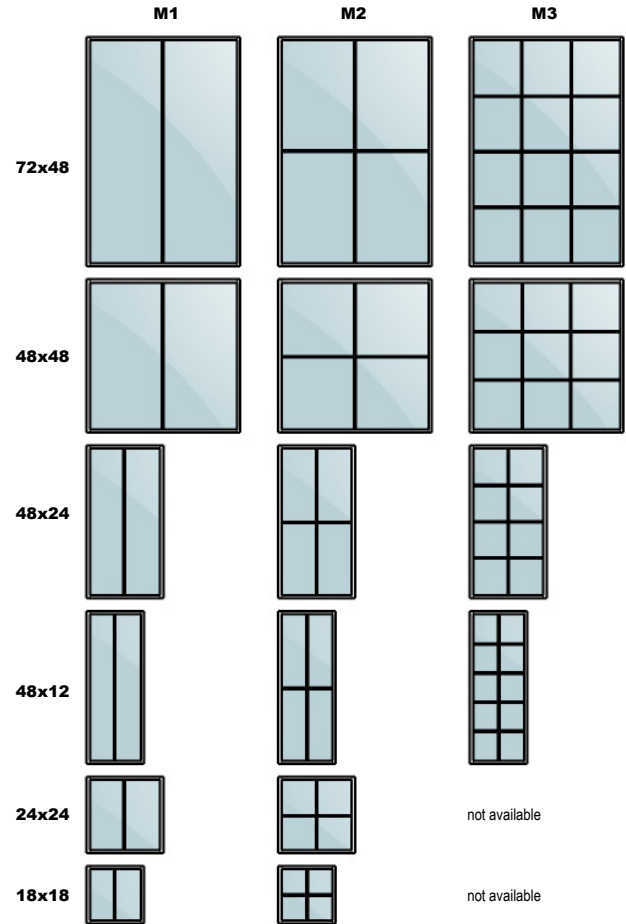

LIGHTGLASS

OPTIONS: NON-FERROUS

Non-ferrous (NF) refers to units that do not contain traces of magnetic materials and are safe for use in environments that require non-magnetic building elements such as MRI spaces.

The non-ferrous option is supplied with remote drivers.

EMI filter(s) by others and must be rated for a minimum of 55VDC and 1.5A for each Class 2 DC Low Voltage circuit. Static color temperature units (2200K, 2700K, 3500K, 4000K, 5000K, 6500K) have one Class 2 DC Low Voltage circuit per unit. Dynamic color temperature units (Tunable White - TW) have two Class 2 DC Low Voltage circuits per unit.

NOTE:
 NF installations require non-ferrous unistrut, by others.

OPTIONS: CHICAGO PLENUM

Chicago Plenum (CP) refers to the City of Chicago Environmental Air (CCEA) rating that ensure the luminaire is inherently airtight: wiring and branch circuit terminations are sealed off and gasketed from the plenum air space.

CP option comes standard with 8-foot wiring whip made with standard 3/8" flexible metal conduit (FMC). Overall unit depth increases to 5.25" (from 3.75") to accommodate the additional wiring hardware requirements.

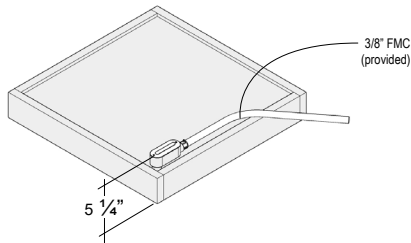

OPTIONS: ANTI-LIGATURE

Anti-Ligature (AL) option is intended for use in the healthcare and behavioral environments where anti-ligature design, shatterproof lenses, gapless installation and tamper resistance are required for patient and staff safety.

The AL option includes a 1/4" thick impact-resistant polycarbonate lens (IK10 rating), tamper-resistant screws with a Pin-In-Torx bit, and OMH-approved tamper-resistant sealant as standard. (see install guide for more detail)

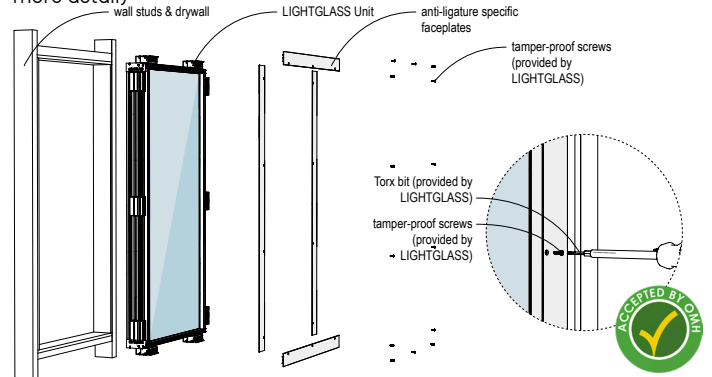



7 Creek Pkwy Suite 700 Boothwyn, PA
215.494.3350
sales@lightglasslighting.com

LIGHTGLASS
lightglasslighting.com